



## VXS Air-Cooled Chassis - 8 Slot

The *FastCluster 3000 SERIES 8-Slot VXS Chassis* is a compact VXS system ideal for use in a lab during the development phase of an application and for deployment in a benign (non-rugged) environment. It features a collapsed dual-star backplane topology delivering high-speed switched fabric performance between one hub and seven payload cards (7+1).

Conforming to the VXS Switched Serial standard (VITA 41) the system provides backward compatibility with existing VME/VME64x boards that do not use the optional VME64x P0 connector. Additionally, VXS systems have dedicated switch slots and a new 6.4 Gbps high-speed P0/J0 connector to enhance the performance of switched fabric signaling with higher bandwidths and improved reliability.

The *FastCluster 3000 SERIES 8-Slot VXS Chassis* offers a turn-key solution coupling system monitoring for DC voltages, fan-fail, and over-temperature warnings with configuration information to simplify the management of the chassis and boards.

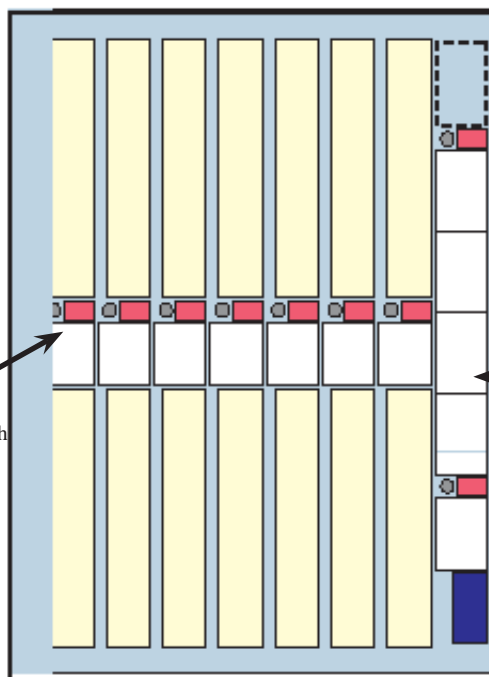

3000 SERIES

- 19" Rackmount
- Standards Compliant Chassis
- VXS (VITA 41.0)
- Advanced Cooling Design
- Front Access to Peripherals
- Monitoring Board
- Air-Cooled

# Specifications

| <b>VXS Air-Cooled 8 Slot Chassis Hardware Specifications</b> |   |
|--|---|
| <b>Backplane</b>   | VXS (VITA 41.x)<br>P0/J0: 7 row RT2 (Multi-Gig connector)<br>J1 & J2: 5 row DIN<br>Switch Slots: RT1 & RT2 data connectors                          |
| <b>Slots</b>   | 8   |
| <b>ENVIRONMENTAL</b>   |   |
| <b>Operating Temperature</b>                                 | 0° C to +40° C (inlet air)  |
| <b>Ambient Air Relative Humidity</b>                         | up to 95% non-condensing  |
| <b>Altitude</b>  | ~300 ft. (~90m) to 10,000 ft. (3048 m)  |
| <b>Shock</b>   | 10g, 11 ms half sine  |
| <b>Random Vibration</b>                                      | 0.002 G <sup>2</sup> /Hz, 20 - 2000 Hz  |
| <b>Storage Temperature</b>                                   | -40° C to +85° C  |
| <b>ELECTRICAL / MECHANICAL</b>                               |   |
| <b>Power Requirements</b>                                    |   |
| <b>AC Input</b>  | 100 - 240 VAC (auto ranging)<br>50/60 Hz; 400 Hz available as an option<br>IEC 320/20 plug on chassis<br>Chassis supplied with NEMA 6-20 power cord |
| <b>Power Supply</b>  | Astec iMP 1500 Watt<br>1200 Watt @ 100 VAC input  |
| <b>PHYSICAL DIMENSIONS</b>                                   |   |
| <b>Height</b>  | 17.22 inches (437.39 mm)  |
| <b>Depth</b>   | 18.56 inches (471.42 mm)  |
| <b>Width</b>   | 11.92 inches (302.77 mm)  |

## Management Plane

The 3000 SERIES expands upon the functionality provided by the environmental sensors incorporated in previous generation products. This new functionality is provided by a dedicated Management Plane implemented through the use of VXS I2C buses. The Management Plane integrates an I2C point-to-point bus for direct communication between each Payload slot and the VXS Switch. Simple management functions on the payload cards support chassis level geographical addressing, optional power sequencing and board fault reporting.

### Management Plane features:

Geographical Addressing  
Slot ID & Chassis ID

Myri-10G Switch  
Out-of-Band Management and  
Monitoring via the  
Fabric Management System (FMS)

Serial Crosspoint Switch Setting  
for XL-Gate's or StarGate's

VXS Payload Power Sequencing  
and Payload Identification (NVRAM)

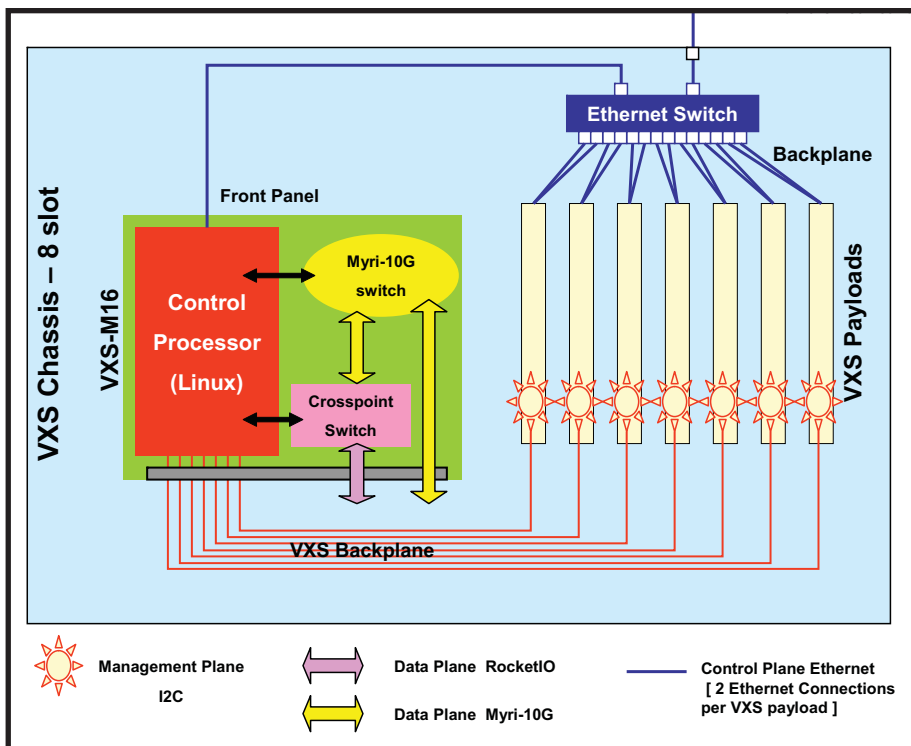

The Control Processor on the VXS Switch Module is used to implement board type sensing (XL-Gate or StarGate) and auto-configuration of the Switch Module via a Serial Crosspoint Switch which connects some of the P0/J0 ports to the Myri-10G switch or to other serial connections on the backplane. Point-to-Point topologies, like mesh or other more specific patterns, can be implemented by simply re-configuring the Serial Crosspoint Switch. This is used to connect the FPGA RocketIO ports across multiple XL-Gates.

# VXS 8 Slot Chassis Configuration Options

|                                       |           | 7x VXS PAYLOADS    |          |   | VXS-M16 Switch Module   |   |
|---------------------------------------|-----------|--------------------|----------|---|-------------------------|---|
| Payload Type                          | VXS Slots | P0/J0 Serial Lanes | Protocol | Point-to-Point Serial Crosspoint Switch (Protocol Agnostic) | Myri-10G 16 Port Switch |   |
| StarGate                              | #7        | 4x                 | Myri-10G |   | 0                       | Configured with all StarGate serial links communicating with Myri-10G 16 Port Switch. Some links are direct, some links pass through the crosspoint switch. |
|                                       |           | 4x                 | Myri-10G |   | 4                       |   |
|                                       | #6        | 4x                 | Myri-10G |   | 2                       |   |
|                                       |           | 4x                 | Myri-10G |   | 15                      |   |
|                                       | #5        | 4x                 | Myri-10G |   | 3                       |   |
|                                       |           | 4x                 | Myri-10G |   | 5                       |   |
|                                       | #4        | 4x                 | Myri-10G |   | 1                       |   |
|                                       |           | 4x                 | Myri-10G |   | 14                      |   |
| - or -                                |           |                    |          |   |                         |   |
| XL-Gate                               | #7        | 4x                 | Myri-10G |   | 0                       | (1) Configured to support a mesh topology with point-to-point serial links between XL-Gates;<br>(2) Configured for broadcast operation.                     |
|                                       |           | 4x                 | RocketIO |   | unused                  |   |
|                                       | #6        | 4x                 | Myri-10G |   | 2                       |   |
|                                       |           | 4x                 | RocketIO |   | unused                  |   |
|                                       | #5        | 4x                 | Myri-10G |   | 3                       |   |
|                                       |           | 4x                 | RocketIO |   | unused                  |   |
|                                       | #4        | 4x                 | Myri-10G |   | 1                       |   |
|                                       |           | 4x                 | RocketIO |   | unused                  |   |
| StarGate                              | #3        | 4x                 | Myri-10G |   | 6                       | Configured with all StarGate serial links communicating directly with Myri-10G 16 Port Switch.  |
|                                       |           | 4x                 | Myri-10G |   | 12                      |   |
|                                       | #2        | 4x                 | Myri-10G |   | 7                       |   |
|                                       |           | 4x                 | Myri-10G |   | 13                      |   |
|                                       | #1        | 4x                 | Myri-10G |   | 11                      |   |
|                                       |           | 4x                 | Myri-10G |   | 10                      |   |
| VXS-M16 Switch Module Front Panel I/O |           |                    |          |   |                         |   |
|                                       | I/O 0     | 4x                 | Myri-10G |   | 8                       |   |
|                                       | I/O 1     | 4x                 | Myri-10G |   | 9                       |   |

A small FastCluster 3000 SERIES 8-slot system (VXS collapsed dual-star architecture) is designed to support up to seven (7) VXS Payloads and one VXS Switch Module. Specifically, the system can accommodate a maximum of four (4) XL-Gate payloads and as many as seven (7) StarGate payloads in two types of slots: Dual Usage Slots for either a StarGate or XL-Gate payload and

Single Usage Slots for StarGate only. This system supports 20 GB/s of peak bi-section bandwidth (data rate of 10+10 Gbits/s per Myri-10G switch port ) across the 7 VXS payloads and two optional plug-in XFP fiber or CX4 copper connections (on VXS Switch front panel).



### *VXS 8-Slot Chassis Ordering Information*

| Product                         | Part Number | Description                                  |
|---------------------------------|-------------|--|
| VXS Air-Cooled Chassis - 8 Slot | 100583-01   | Air-Cooled Chassis with 8 Slot VXS Backplane |
|                                 |             |  |

**CSP Inc.**  
 (978) 663-7598  
 www.cspi.com  
 Email: info@cspi.com

The information contained herein is subject to change without prior notice. For the latest detailed information contact your representative.

3005-01 11/09

Myri-10G is a trade name of Myricom, Inc. WorkBench is a registered trademark of Wind River. YDL, Yellow Dog Linux, is a registered trademark of Fixstars Solutions. Other product names are the trademarks or registered trademark of their respective companies. © CSP Inc. 2009.