

StarGate 3120 & 3120D

PowerPC VXS Payload

The StarGate 3120 & 3120D are the first FastCluster 3000 SERIES PowerPC AltiVec VXS payloads incorporating the latest improvements in multi-core processing and fabric interconnect with Myricom® Myri-10G 10-Gigabit Ethernet clustering technology. Delivering breakthrough performance, low power consumption and low latency, the StarGate operates in a standard VXS backplane with a companion Myri-10G VXS Switch Module.

Highlighting overall system performance, the StarGate 3120 & 3120D incorporate the Freescale single/dual-core PowerPC 8641/D with AltiVec™ and a high performance dual channel memory (DDR2 64-bit @ 533 MHz per channel) offering a five-fold performance improvement in memory bandwidth over the previous 2000 SERIES PowerPC architecture.

At the heart of the 3000 SERIES platform is the Myri-10G interconnect serving the single/dual-Core PowerPC's nodes to form a high performance embedded cluster with scalable bi-section bandwidth. Each StarGate implements two independent Myri-10G nodes. Each node features a Myri-10G NIC (network processor and firmware) supporting a Myri-10G connection that delivers a 10+10 Gbits/s data rate and off-loads the core processor (CPU) from network protocol processing. This implementation minimizes host CPU utilization and enables low-latency kernel bypass communication directly with the application. Myri-10G NIC's maximize throughput by implementing PCI Express and XAU at the physical layer. The NIC connects to PowerPC's through 8-lane PCI-Express, a 2+2 GigaByte/s full-duplex I/O fabric that is fast enough to keep up with the 1.25+1.25 GigaByte/s network port.

Leveraging the new features offered by the VITA 41 standard, the StarGate supports the traditional P1 and P2 connectors and retains a 6U VME form factor, while boosting performance for serial interconnect with the enhanced VXS P0 connector. The new VXS P0 connector supports two Myri-10G connections, each delivering a 10+10 Gbit/s data rate, for a total of 5 GBytes/s per payload. This represents a five-fold improvement in speed over the 2000 SERIES implementation.

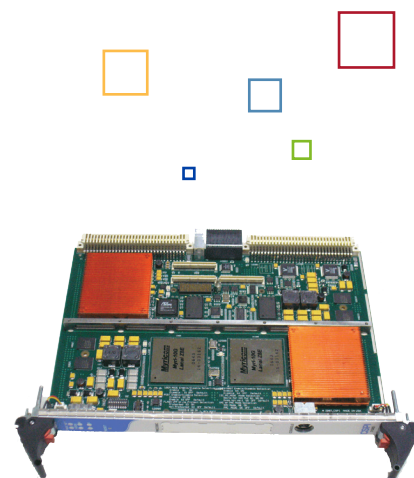

KEY FEATURES

- 8641/8641D PowerPC Processing Nodes
- VXS (VITA 41.0)
- Myri-10G Clustering
- PMC/XMC Expansion Slot
- High Availability
- Air-Cooled or Conduction-Cooled

StarGate 3120 & 3120D

Dual Core PowerPC with Altivec

The Freescale PowerPC 8641D will provide the 3000 SERIES with a logical integration of the two processing cores, an Altivec Unit, DDR2 memory controller, and a PCI Express interface on a chip offering considerable improvement in clock speed, core to core interconnect for SMP implementation, and I/O to the fabric delivering improved Gflops/Watt.

The StarGate architecture supports applications with both complex processing and I/O requirements. The L2 cache configuration also enables data locality and concurrent operations of the two e600 cores with minimal data collision at the MPX Coherency Module (MCM).

For a streaming node, the availability of two PCI Express interfaces (XMC to sensor interface, Myri-10G NIC for the fabric) enables the efficient implementation of streaming data (sensor input or output) with a single core (8641) running Linux or VxWorks® kernel for hard real time applications.

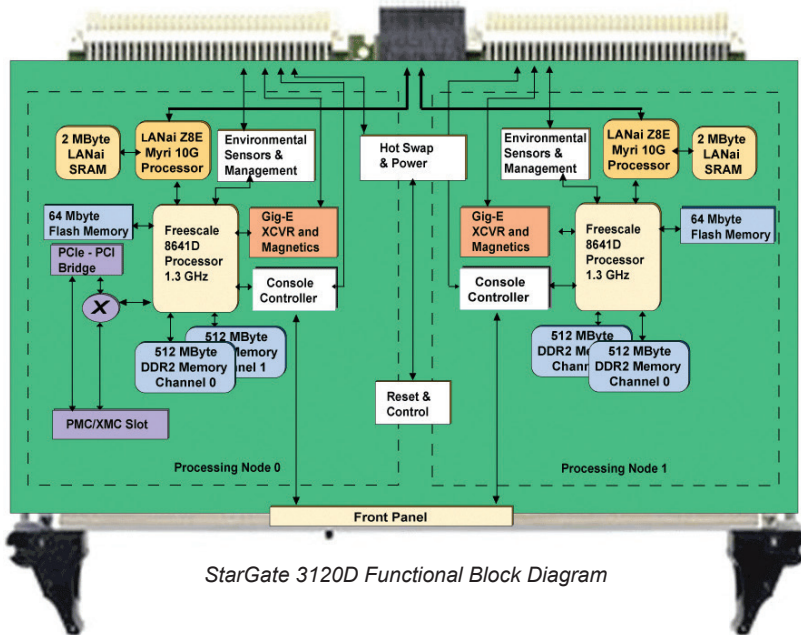

StarGate 3120D Functional Block Diagram

Myri-10G Data Plane

Maximum performance is achieved when the Myri-10G NIC technology on the StarGate 3120 & 3120D is configured in MX Myri-10G mode and used in conjunction with a Myri-10G VXS Switch Module.

However, the Myri-10G NIC can also be used in 10 Gigabit Ethernet mode to support 10GbE interoperability to any 10GbE compliant device (10GbE switch, 10GbE server, 10GbE

raid disk). Specific examples of applications of interoperability with other 10GbE devices include iSCSI raid disk support, 10GbE sensor interface, and other servers with built-in 10GbE connectivity on the embedded platform.

Management Plane

The StarGate 3120 & 3120D payloads implement high availability features to support mission critical applications requiring blade replacement without human interaction beyond insertion in the VXS slot. These features are combined into a built-in VXS I2C Management Plane supporting: live insertion, Power on Self Test (POST), self-boot, geographical addressing, and board identification. In addition to the Myri-10G Data Plane, the 3000 SERIES payloads implement an Ethernet Control Plane supporting Out-of-Band cluster management via the Myri-10G Fabric Management System.

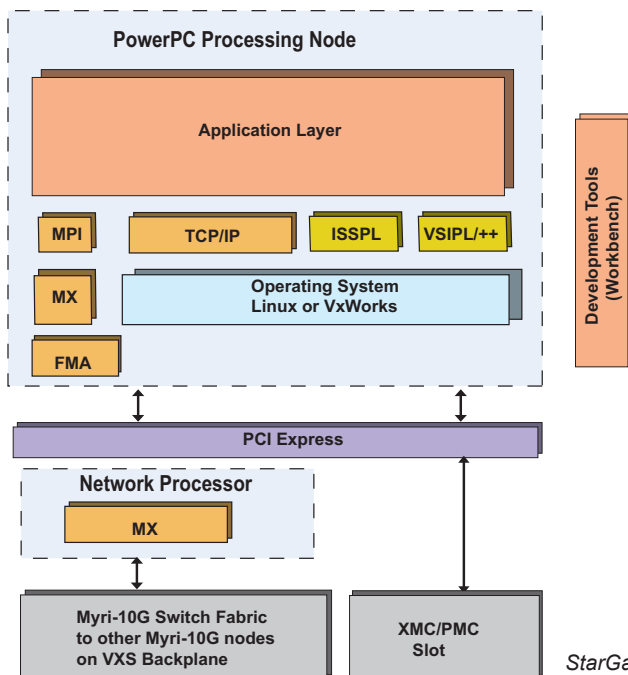

StarGate Processing Node Software Architecture

Hardware Specifications

KEY SPECIFICATIONS

Processing Nodes per Board	Two
Processor Node Options	One Single Core Freescale MPC8641 with AltiVec (Model 3120) or One Dual Core Freescale MPC8641D with AltiVec (Model 3120D)
Processor Clock	1.33 GHz
Cache	L1 Cache: 32KB/32KB instruction/data; L2 Cache: 1 MB (per core)
Flash Memory	64 MB per processing node (32 MB available to user)
SDRAM	Two 512 MB DDR2 Memory Channels @ 533 MHz per processing node for a total of 2 Gbytes per board

FRONT PANEL CONNECTIONS

Serial Console (debug)	Two Serial Console Interfaces (one per processing node)
------------------------	---

BACKPLANE: VXS (VITA 41.0)

J0/P0	Two Myri-10G Serial Links (10+10 Gbits/s data rate)
J2/P2	Two 10/100 Base-T Ethernet Connections (one per processing node) Two Serial Console Interfaces (one per processing node)

NETWORK COMMUNICATION

Network Standard	Myri-10G
Network Processor	LANai Z8E with 2 MB External SRAM running @ 300 MHz

EXPANSION SLOTS

XMC/PMC	One slot per board; Supports 33/66/133 MHz operations @ 3.3 Volt Signaling PMC expansion is IEEE P1386.1, and PCI-X compliant XMC expansion is ANSI/VITA 42.3-2006, XMC PCI Express Protocol compliant.
---------	---

ENVIRONMENTAL (Air-cooled)

	StarGate 3120D (100590-03)	StarGate 3120D (100590-04, with stiffener)
Operating Temperature	0° C to +55° C (inlet air)	0° C to +55° C (inlet air)
Ambient Air Relative Humidity	up to 95% non-condensing	up to 95% non-condensing
Maximum Altitude**	10,000 ft. (3048 m)	10,000 ft. (3048 m)
Shock	10 Gs @ 11 ms half sine	20 Gs @ 11 ms half sine
Random Vibration	0.002 g ² /Hz, 10 - 2000 Hz	0.04 g ² /Hz, 10 - 2000 Hz
Sinusoidal Vibration	2 G's, 5-500 Hz, swept sine	4 G's, 5-500 Hz, swept sine
Storage Temperature	-40° C to +85° C	-40° C to +85° C

**Ambient Temperature, Airflow and Altitude parameters can be traded off among each other. Consult Factory for more information.

ELECTRICAL (Power Requirements*)

	StarGate 3120	StarGate 3120D
5.0 Volts	48 Watts Max	52 Watts Max
3.3 Volts	38 Watts Max	42 Watts Max
12 Volts	< 1 Watt	< 1 Watt

*Note: these numbers do not include any XMC/PMCs that may be installed on the board

PHYSICAL DIMENSIONS

Packaging Standard	6U VME64 Extension (ANSI/VITA 11-1997) Form Factor
Height	9.2 inches (233.4 mm)
Depth	6.3 inches (160.0 mm)
Width	0.8 inches (19.8 mm)
Slot Pitch	0.8"
Weight	1.64 lbs. (weight will vary depending on configuration)

Specifications

SOFTWARE SPECIFICATIONS

Operating Systems	Wind River® General Purpose Platform, Linux Edition (based on the Linux 2.6 distribution) Wind River® General Purpose Platform, VxWorks® Edition Terra Soft Solutions' Yellow Dog Linux
Message Passing Interface	MPICH-MX and Fabric Management System (FMS) running on the processing node provide support for the Myri-10G interconnect
Development Tools	A Wind River® Workbench GNU Toolset
Signal Processing Libraries	ISSPL VSIPL
AltiVec Optimized Signal Processing Libraries	ISSPL VSIPL

PART NUMBERS

100580-01	StarGate 3120 - 2 GB. Air-Cooled 6U VXS Payload with two PowerPC 8641 Myri-10G processing nodes operating at 1.3 GHz and 2 GB Memory
100590-03	StarGate 3120D - 2 GB. Air-Cooled 6U VXS Payload with two PowerPC 8641D (dual core) Myri-10G processing nodes operating at 1.3 GHz and 2 GB Memory (no stiffener)
100590-04	StarGate 3120D - 2 GB (Rugged Version). Same as above but with stiffener.
Consult Factory	StarGate 3120D - 4 GB. Same as above but with 4 GB memory.
Consult Factory	StarGate 3120 - 2 GB. Conduction-Cooled 6U VXS Payload with two PowerPC 8641 Myri-10G processing nodes and 2 GB Memory
Consult Factory	StarGate 3120D - 2 GB. Same as above but with two PowerPC 8641D (dual core) Myri-10G processing nodes and 2 GB Memory

The information contained herein is subject to change without prior notice. For the latest detailed information contact your representative at +1 (978) 663-7598 or visit www.cspi.com.

Wind River, VxWorks and Workbench are registered trademarks of Wind River. Myricom is a registered trademark of CSP Inc. © CSP Inc. 2015.

