

VXS-M16 Switch Module

The **VXS-M16 Switch Module** is designed to support a small FastCluster 3000 SERIES 8-slot system (VXS collapsed dual-star architecture) with seven StarGate and XL-Gate payloads. The VXS Switch Module features a low power, high density, Myri-10G 16-port crossbar switch supporting up to 16 connections for processing nodes and I/O on the fabric. This system supports 20 GB/s of peak bi-section bandwidth (data rate of 10+10 Gbits/s per Myri-10G switch port) across the 7 VXS payloads and two optional connectors on the VXS Switch front panel. The switch module is available in two configurations: one has two plug-in XFP fiber connections, the other has two copper transceivers.

In addition to Myri-10G, the VXS Switch module has a protocol agnostic serial crosspoint switch to configure direct point-to-point serial connections between the FPGA units on the XL-Gate VXS payload modules. Control and Management functions are performed by a control processor on the switch board enabling the static configuration of the crosspoint switch, the monitoring of the Myri-10G switch and the monitoring of vital signs (power and temperature) of the switch module.

20 GBytes/sec
Bi-section Bandwidth

Myri-10G 16 Port
Switch

VXS (VITA 41.0)

Fiber or Copper
Front Panel
Transceivers

Protocol Agnostic
Serial Crosspoint
Switch

Air-Cooled or
Conduction-Cooled

3000 SERIES

VXS Switch Module usage with 8 Slot Chassis

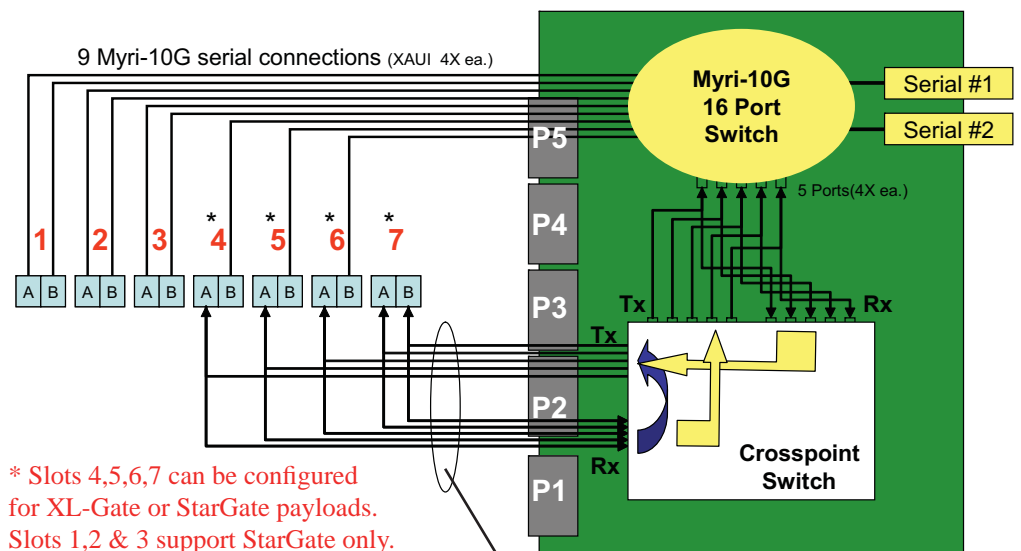

20 protocol agnostic serial lanes, 1x each (transmit and receive), four lanes per P0 connector (A or B)

VXS-M16 Switch Module

Low latency, FPGA-to-FPGA Communication via a "Protocol Agnostic" Serial Crosspoint Switch. The user configurable switch implements direct point-to-point serial connections for high speed data flow between FPGA's on the VXS backplane

High Bandwidth for Increased Scalability while retaining a traditional 6U form factor.

The new MultiGig RT high-speed differential signaling connectors support 14 10-Gigabit serial connections on the VXS Backplane. Each port implements the XAUI physical layer with 4x serial links delivering a 12.5 Gbaud signaling rate (4 x 3.125 Gbps) and a 10 Gigabit/sec data rate.

VXS (VITA 41) Backplane

Front Panel

10 Gigabit Interconnect

via a monolithic, low power, low latency Myri-10G 16-Port Serial Crossbar Switch providing 40-Gigabit per second communication between 3000 SERIES VXS payloads.

10-Gigabit Front Panel Serial I/O

Two serial ports on the front panel (optional) support Fiber (XFP) or Copper Transceivers for sensor I/O and extending the switch fabric interconnect.

Each VXS switch module supports up to seven VXS payloads with Hybrid Compute Nodes based on the Freescale 8641D and Xilinx Virtex-5 FPGA's.

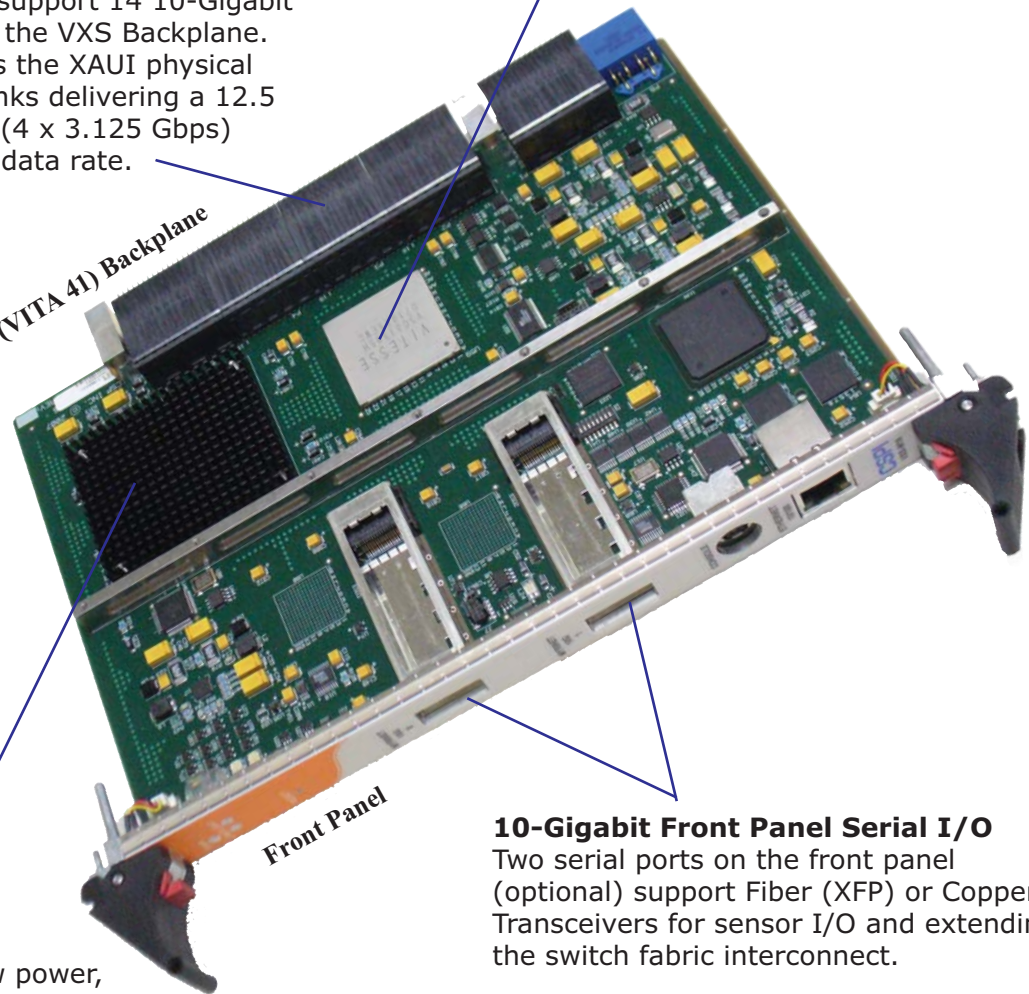

Specifications

Myri-10G 16-Port Switch

Each VXS switch board integrates a low power, high density Myri-10G 16-port serial cross-bar switch. The Myri-10G switch leverages the XAUI Physical-layer de facto standard for 10-Gigabit/sec data rate communication. Each Myri-10G XAUI port (4 serial, 8b/10b-encoded links each way) delivers 12.5 Gbaud signaling rate (4 x 3.125) and 10 Gigabit/sec data rate. The Myri-10G switch fabric implements byte-level flow control, source-based routing and cut-through switching.

Xilinx Serial Interconnect

In addition to the Myri-10G 16 port crossbar switch, each 3000 SERIES VXS Switch Module features a “protocol agnostic” serial crosspoint switch that can be used to implement point-to-point serial interconnect. The user configures the crosspoint switch to optimize the FPGA data flow across payloads, leveraging the Xilinx RocketIO ports without incurring the cost of a specific backplane design. Mesh or other point-to-point topologies can be configured as needed.

Fabric Management System

The FastCluster 3000 SERIES VXS Switch Module is designed with an Integrated Out-of-Band Control Plane and a Fabric Management System [FMS]. FMS is a collection of tools and processes used to manage the Myri-10G network. FMS provides centralized diagnostic monitoring of the Myri-10G fabric from a command-line interface. FMS consist of one FMS server process and many Fabric Management Agent (FMA) processes, one running on each Myri-10G node in the network. The FMS/FMA system includes a mapping function.

FMS relies on a database which describes the network connections. Once this baseline description of the network is created,

3000 SERIES VXS-M16 Technical Specifications

3000 SERIES VXS-M16 Technical Specifications		
SWITCH TECHNOLOGY		
Myri-10G Crossbar Switch	16 Connections @ 10 Gb/s full duplex, non blocking	
Serial Crosspoint Switch	Serial links operating @ 3.125 Gbps NRZ Data Rate	
FRONT PANEL (* The VXS-M16 comes in two versions: one supports fiber, the other supports copper)		
XFP Transceivers*	2 (optional) Plug-in Modules with Myri-10G over Fiber	
Copper Transceivers*	2 (optional) with Myri-10G over Copper	
Ethernet	10/100Base-T Ethernet RJ45 Connector	
CONTROL PROCESSOR		
MPC8270	Provides support for FMS	
BACKPLANE		
VXS (VITA 41.x)	Collapsed Dual-Star Switch Implementation	
ENVIRONMENTAL (Air-cooled)		
Operating Temperature	0° C to +55° C (inlet air)	
Ambient Air Relative Humidity	up to 95% non-condensing	
Maximum Altitude**	10,000 ft. (3048 m)	
Shock	20 Gs @ 11 ms half sine	
Random Vibration	0.04 g ² /Hz, 10 - 2000 Hz	
Sinusoidal Vibration	4 G's, 5-500 Hz, swept sine	
Storage Temperature	-40° C to +85° C	
**Ambient Temperature, Airflow and Altitude parameters can be traded off among each other. Consult Factory for more information.		
ELECTRICAL (Power Requirements)		
Electrical Power	CX-4 Interfaces	XFP Interfaces
3.3 Volts	None	None
5.0 Volts	30 Watts	37 Watts (estimated)
12 Volts	None	None
PHYSICAL DIMENSIONS		
Packaging Standard	6U VME64 Extension (ANSI/VITA 1.1-1997)	
Height	9.2 inches (233.4 mm)	
Depth	6.3 inches (160.0 mm)	
Width	0.8 inches (19.8 mm)	
Slot Pitch	0.8"	
Weight (Copper)	1.15 lbs. (with CX-4 Interfaces)	
Weight (Fiber)	1.43 lbs. (with Fiber XFP Transceivers installed)	

it is possible to monitor links and switches and report discrepancies between the observed network state and the desired network state. FMS can be configured either for queries or to automatically generate an alert when error conditions are detected in the Myrinet fabric. The FMS has connectivity to all the Myri-10G nodes in the FastCluster via an Ethernet control plane and has access to its database. Alerts are created when certain exception events occur, i.e., {link_down}, {SRAM parity error on a NIC}, {switch_xbarport_disabled}.

FastCluster 3000 SERIES

Combining flexibility and high speed serial data rates, the VXS-M16 Switch Module coupled with XL-Gate and StarGate payloads creates an ideal solution for general purpose digital signal processing applications such as: SIGINT, surveillance radar and sonar.

VXS-M16 Ordering Information

	Part Number	Description
Air-Cooled		
VXS Switch - Universal (VXS-M16)	100592-01	Air-Cooled 6U VXS Switch Module supporting up to two (2) optional transceivers on the front panel providing Myri-10G over XFP Fiber or Copper
VXS Switch Copper (VXS-M16/C)	Consult Factory	Air-Cooled 6U VXS Switch Module supporting 10GBase-CX4 copper on the front panel providing Myri-10G over copper
Conduction-Cooled		
VXS Switch - Universal (VXS-M16)	Consult Factory	Conduction-Cooled 6U VXS Switch Module supporting up to two (2) optional transceivers on the front panel providing Myri-10G over XFP Fiber or Copper
VXS Switch Copper (VXS-M16/C)	Consult Factory	Conduction-Cooled 6U VXS Switch Module supporting 10GBase-CX4 copper on the front panel providing Myri-10G over copper
Accessories		
Fiber Cables	101002-xx	LC Fiber Cables (where -xx represents the length)
Copper Cables	101003-xx	CX4 Copper Cables (where -xx represents the length)
Transceivers	101000-01	10G XFP Fiber LC Transceiver
	101001-01	10G Copper CX4 Transceiver
	101004-01	10G SFP+ Fiber LC Transceiver

CSP Inc.

(978) 663-7598

www.csipi.com

Email: info@csipi.com